

## PIM Shield Rail Mechanical Loading

### INTRODUCTION

The PIM Shield Cable Support Rail is a low passive intermodulation (PIM) aluminum strut designed to support RF cables and mechanical equipment within the high-risk PIM zone near antennas at cell sites. Custom Channel Runner assemblies have been developed to attach PIM Shield rails to structural members at the site and to attach cable support hardware to the rail. Each Channel Runner assembly includes UV stable, glass-filled Nylon molded insulators to prevent metal-to-metal contact between the rail, mounting hardware and mounting surfaces.

ConcealFab sells complete cable support mounting kits including 12-inch or 24-inch rails along with galvanized steel pole mounting brackets to secure the rail to antenna mounting pipes. Wall mounting brackets are also available for securing rails to walls or flat surfaces.

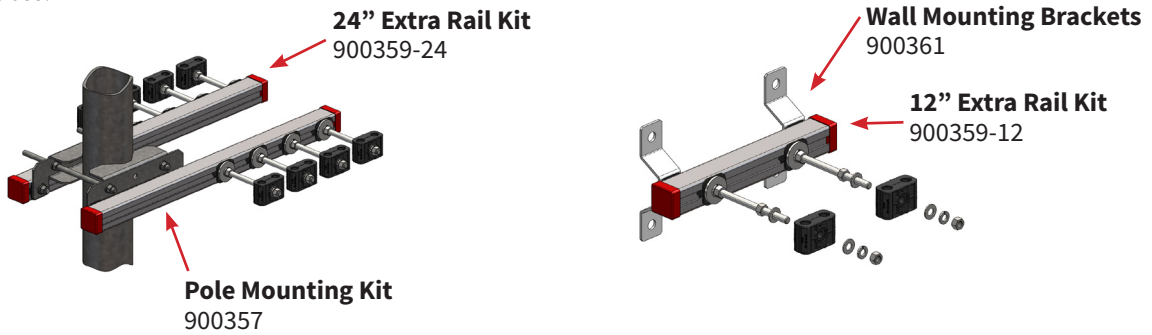

In addition, ConcealFab sells the extruded aluminum rail material by itself in 6-FT lengths. Cross-over kits and pole mounting kits are available to enable customers to create custom mounting frames for securing mechanical equipment at sites.

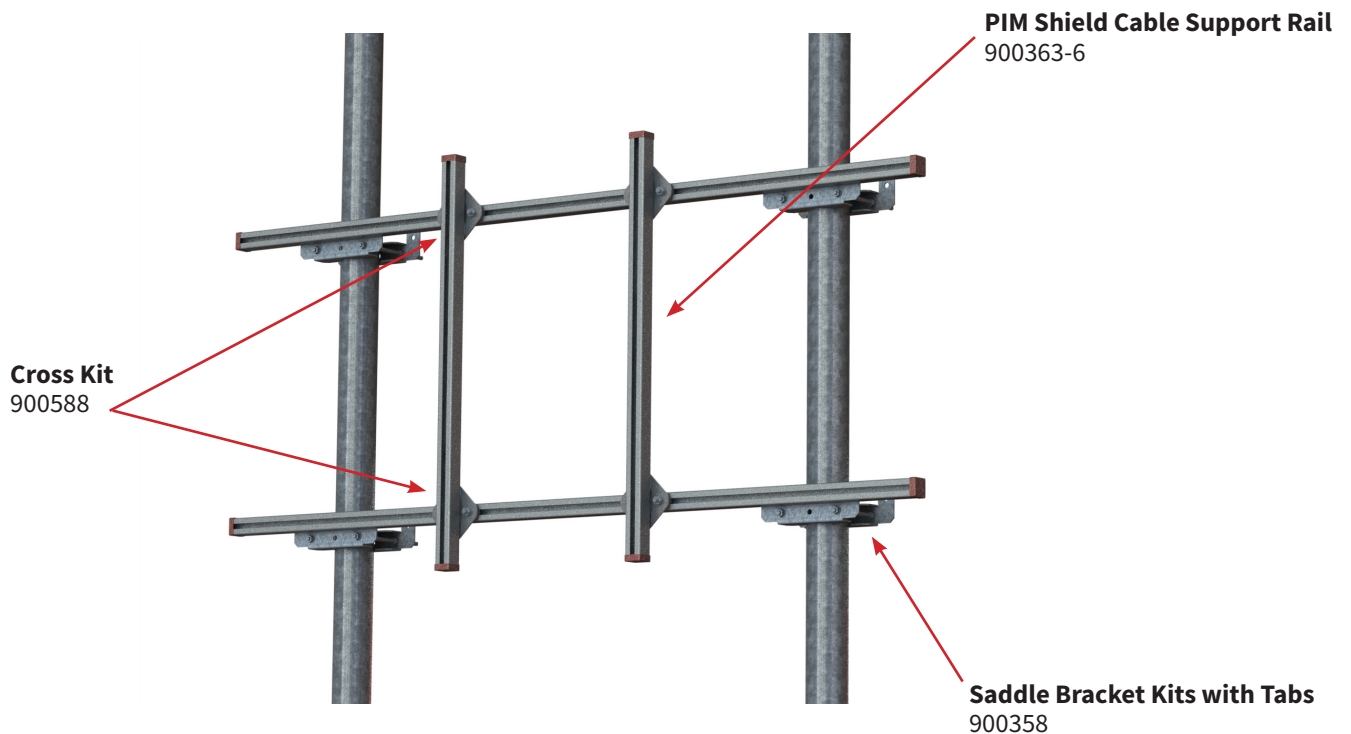

For structural properties of the aluminum rail, please reference datasheet 900363-6. These values can be used to evaluate maximum stress levels within the rail due to applied loads. This application note presents uniform beam load calculations as well as data showing the strength of rail system connections using ConcealFab Channel Runner assemblies.

**RAIL CONNECTIONS**

Heavy gauge steel test fixtures were designed to secure the rail while loads were applied to individual Channel Runner assemblies using Satec Systems Model Apex 22EMF tensile test equipment. Three different test fixtures were developed to apply loads in all three orthogonal axes. Thermocouples mounted to the steel test fixture verified when the assembly reached the required test temperature.

The M10 Channel Runner assemblies were torqued to 15 FT-LB according to the installation instructions using ConcealFab tool 900412.

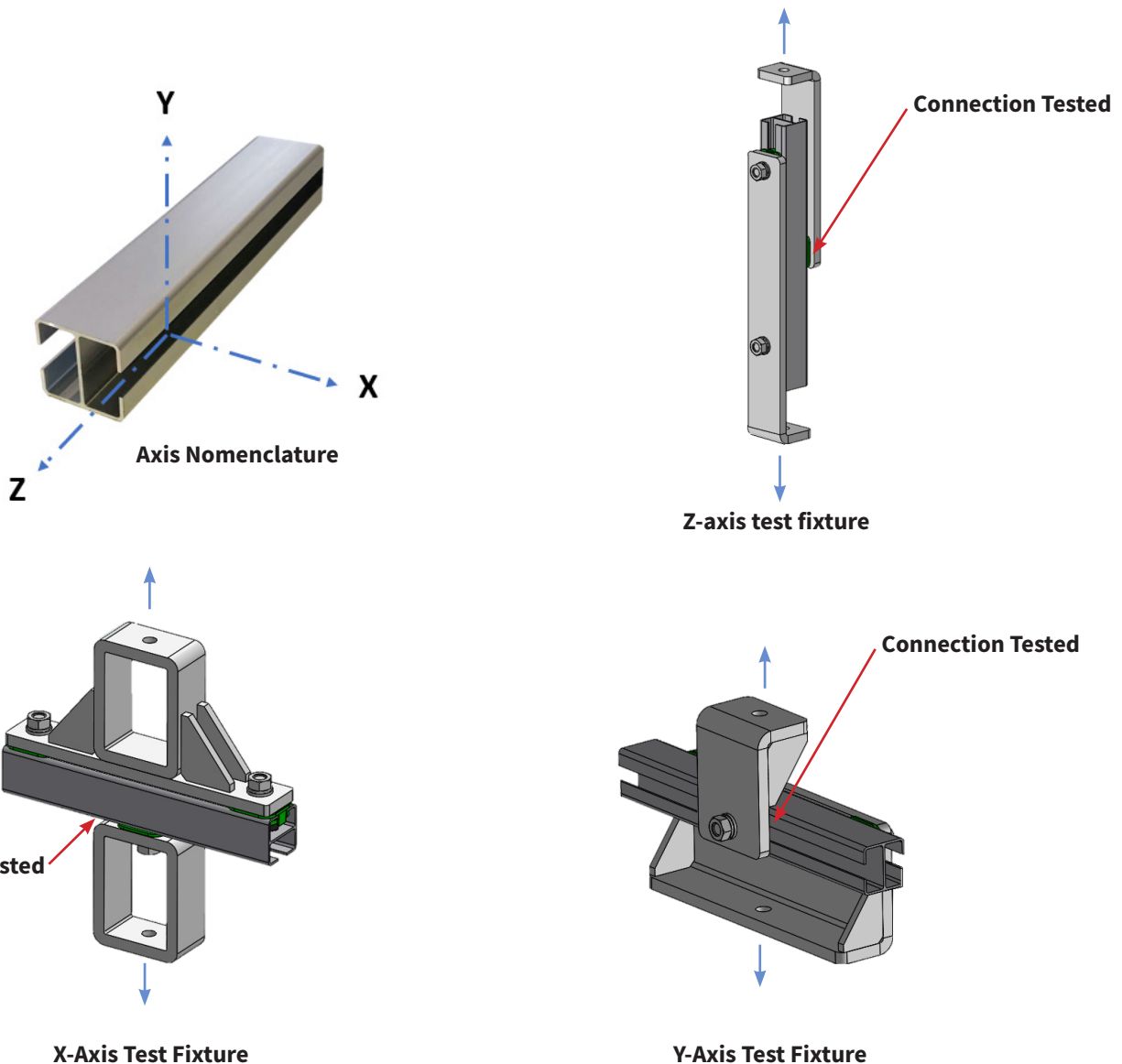



X-Axis Test



Y-Axis Test



Z-Axis Test

**RESULTS:**

X-AXIS TESTS:			
Sample	Temperature	Load (lbs.)	Failure Mode
1	+70°C	1160.0	Plastic Deformation of Rail
2	+70°C	1111.2	
3	-40°C	1492.8	
4	-40°C	1214.2	

Y-AXIS TESTS:			
Sample	Temperature	Load (lbs.)	Failure Mode
1	+70°C	1507.7	Plastic Deformation of Rail
2	+70°C	1541.9	
3	-40°C	1484.2	
4	-40°C	1554.2	

Z-AXIS TESTS:			
Sample	Temperature	Load (lbs.)	Failure Mode
1	+70°C	216.6	Channel Runner Slipped Inside Rail
2	+70°C	199.3	
3	-40°C	599.4	
4	-40°C	644.2	

It is not surprising that the weakest support direction is the Z-axis since support in this direction relies solely on friction between the channel runner and the rail to resist movement. Proper assembly torque is essential to prevent slipping when loaded in this direction. When supporting loads in the Z-axis, multiple connection points / channel runner assemblies should be used to multiply the load carrying capability of the system.

Applying a factor of safety of 2, loads should be no greater than the values shown for individual connections to the rail in the axis indicated.

AXIS	MAXIMUM DESIGN LOAD PER CONNECTION
X	500 lbs.
Y	700 lbs.
Z	100 lbs.

### UNIFORM BEAM LOAD CALCULATIONS

Loads in the following table are given as the total uniform load (W) in pounds. To calculate the uniform load (w) in pounds per foot or pounds per inch, divide the table load by the span. Calculations assume a simply supported beam and a factor of safety of 1.67 relative to the yield stress of the beam material.

Loads under the column headings of “Span / 180”, “Span / 240” and “Span / 360” are provided for installations in which deflection of the rail must be limited. Actual deflection from these preset ratios equals the span divided by the number 180, 240 or 360.

SPAN (IN)	MAX. ALLOWABLE UNIFORM LOAD (LBS)	DEFLECTION AT UNIFORM LOAD (IN)	UNIFORM LOADING AT DEFLECTION		
			SPAN/180 (LBS)	SPAN/240 (LBS)	SPAN/360 (LBS)
24	922	0.06	748	561	374
36	615	0.13	333	249	166
48	461	0.22	187	140	94
60	369	0.35	120	90	60
72	307	0.50	83	62	42
84	263	0.68	61	46	31
96	231	0.89	47	35	23
108	205	1.14	37	28	18
120	184	1.40	30	22	15