

900731-24

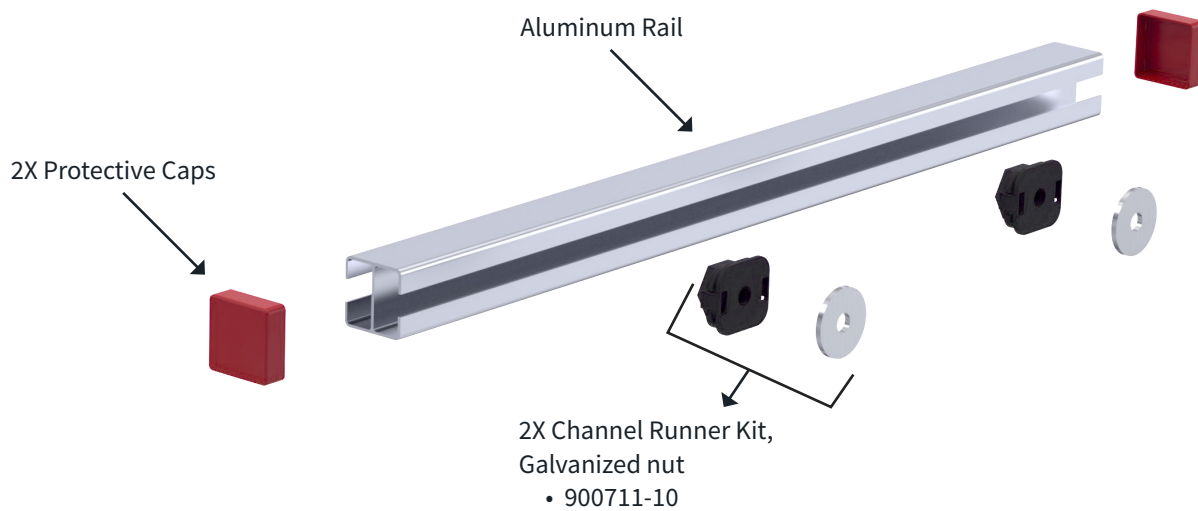

## SPECIFICATIONS

For patents see [www.cf-pat.com](http://www.cf-pat.com)

<b>General</b>	PIM Shield Cable Support Rails provide a low passive intermodulation mounting system to secure multiple Cable Support Blocks (sold separately) in high risk PIM zones. The 900731-24 Rail Kit includes one extruded aluminum rail plus the hardware required to secure the rail to a 009718-01 or 009718-02 Cable Support Bracket (sold separately).
<b>Rail dimensions</b>	24.0-inch x 1.5-inch x 1.5-inch
<b>Rail attachment hardware</b>	3/8-16 galvanized steel nut
<b>System PIM performance (when installed at next higher assembly)</b>	IM3 <-100 dBm when tested in accordance with IEC 62037-8, near field test, 2x 20W test tones, while subjected to dynamic stimulus. To achieve specified PIM performance, torque hardware to 10 FT-LB (ConcealFab tool 900053).
<b>Rail material</b>	Extruded aluminum with clear anodize finish
<b>Channel runner material</b>	UV stable, glass filled Nylon
<b>Operating temperature</b>	-40°C to +70°C
<b>Case dimensions</b>	9.5-inch x 6-inch x 27-inch
<b>Case dimensions</b>	14.2 lb.
<b>Qty per case</b>	10