

MECHANICAL OUTLINE

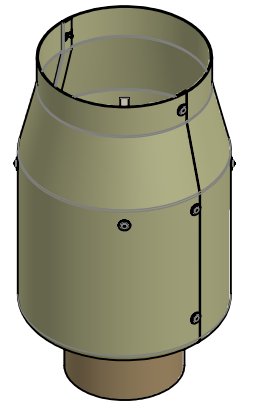

SCALE 1:16

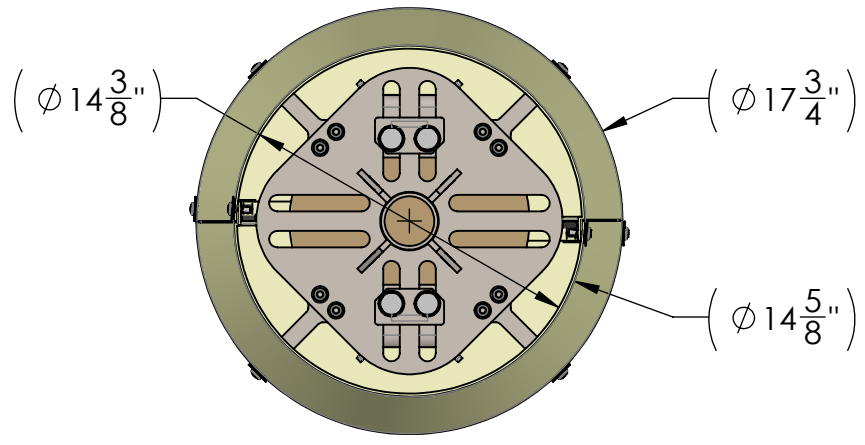
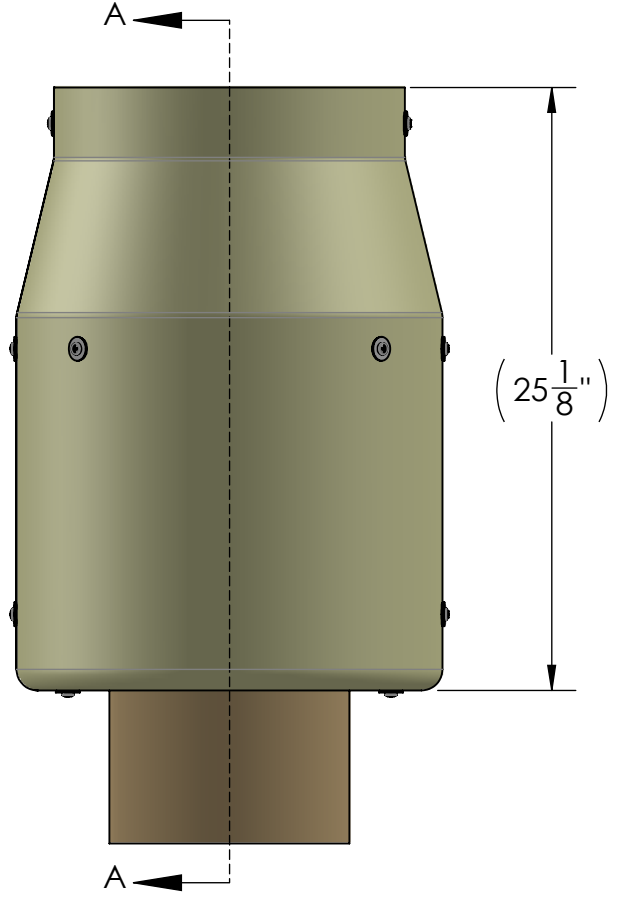

ARRANGEMENT FITS POLES
Ø 5-1/4" TO Ø 7-1/4"

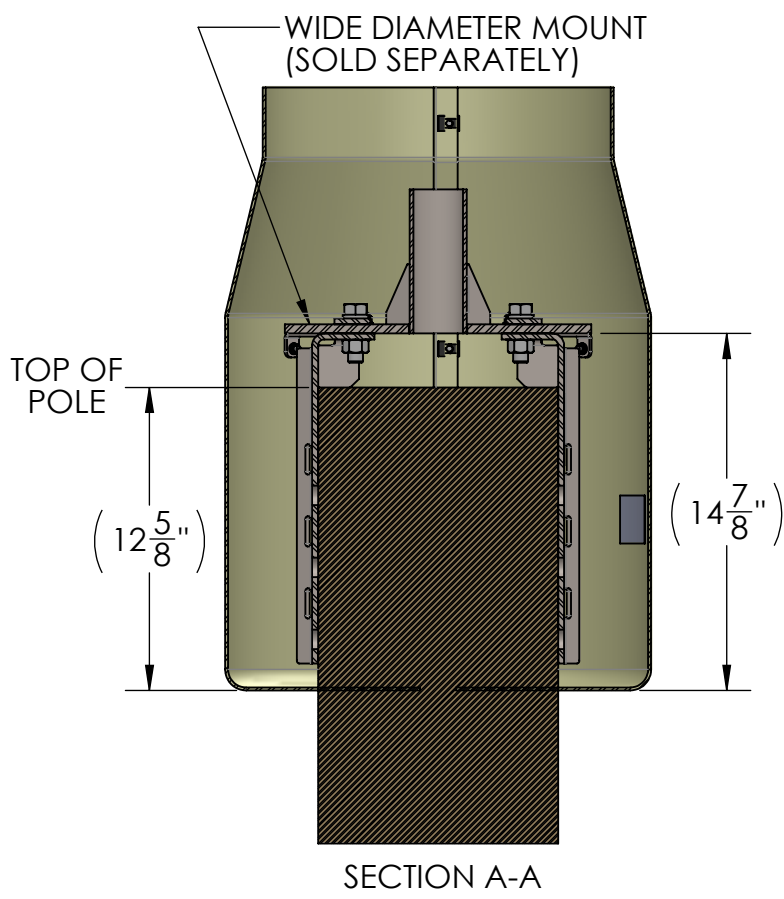

SECTION A-A

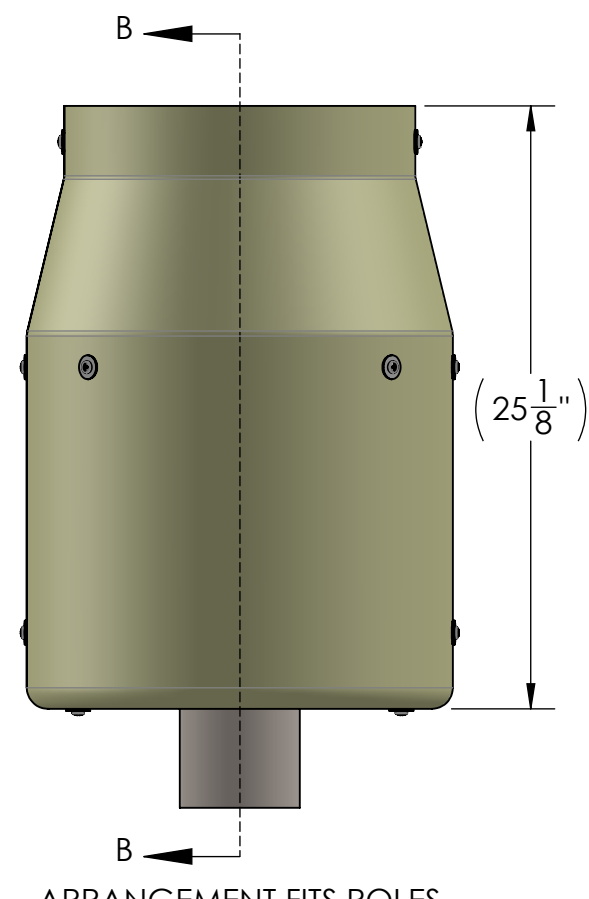

ARRANGEMENT FITS POLES
Ø 7-1/4" TO Ø 14-1/8"

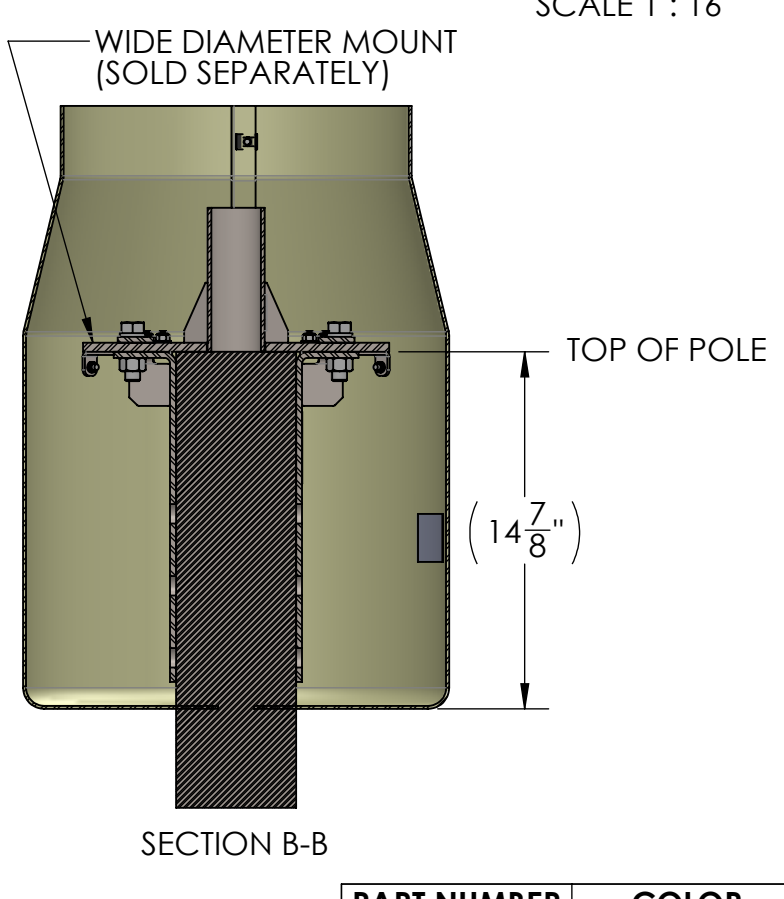

SECTION B-B

PART NUMBER	COLOR
900021-1	BLACK
900021-2	BROWN
900021-3	GRAY
900021-4	SILVER

ConcealFab
Corporation

10205 FEDERAL DRIVE
COLORADO SPRINGS, CO 80908
PH: 719-599-3400 FX: 719-599-0057
SALES@CONCEALFAB.COM

PROPRIETARY INFORMATION
USE, REPRODUCTION, OR DISCLOSURE IS SUBJECT TO RESTRICTIONS SET FORTH IN NON-DISCLOSURE AGREEMENTS AND PERTINENT CONTRACTUAL DOCUMENTS.
© 2017 ConcealFab Corp - All Rights Reserved

DO NOT SCALE DWG

DIMENSIONS ARE IN INCHES

MODELED BY:	ALB	DATE:	09/04/19
DRAWN BY:	ALB	DATE:	09/04/19
CHECKED BY:	JAM	DATE:	09/04/19

TITLE: 16" CABLE CONCEALMENT SHROUD, WIDE DIAMETER MOUNT

SCALE: 1:8 SHEET SIZE: B SHEET: 1 OF 2

SALES NUMBER: 900021-F

APPROXIMATE WEIGHT	9.03 LBS
--------------------	----------

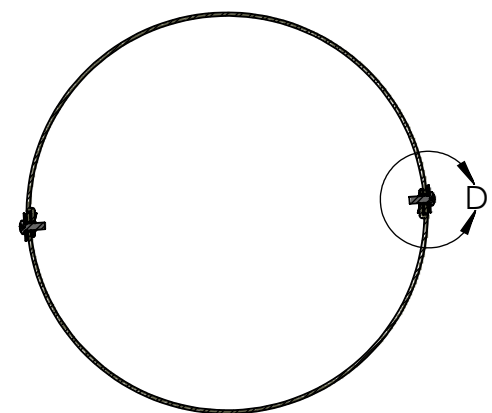
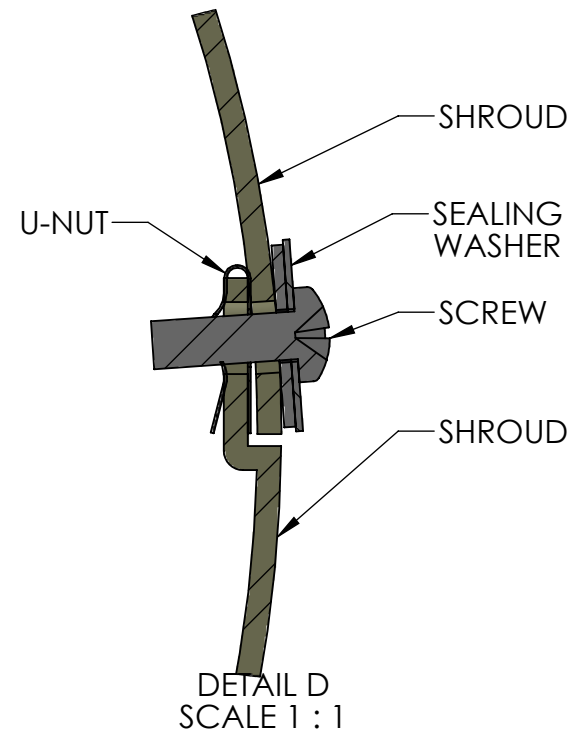
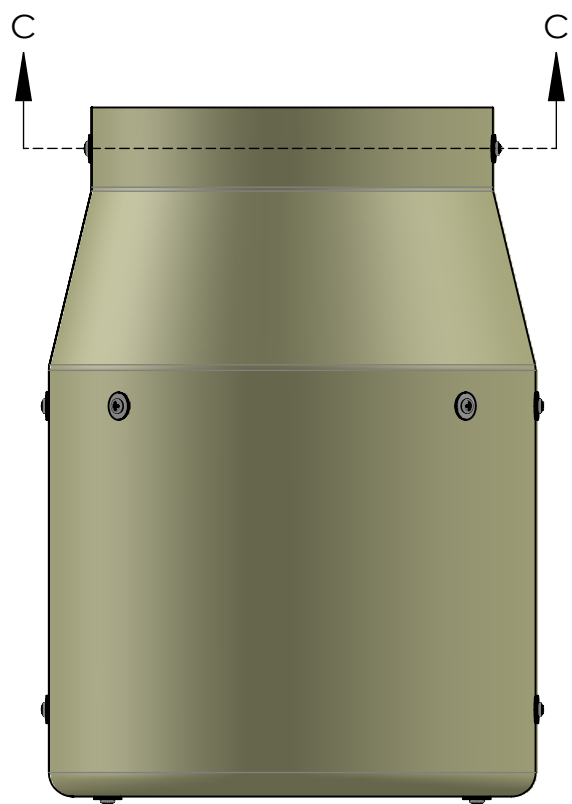

SECTION C-C

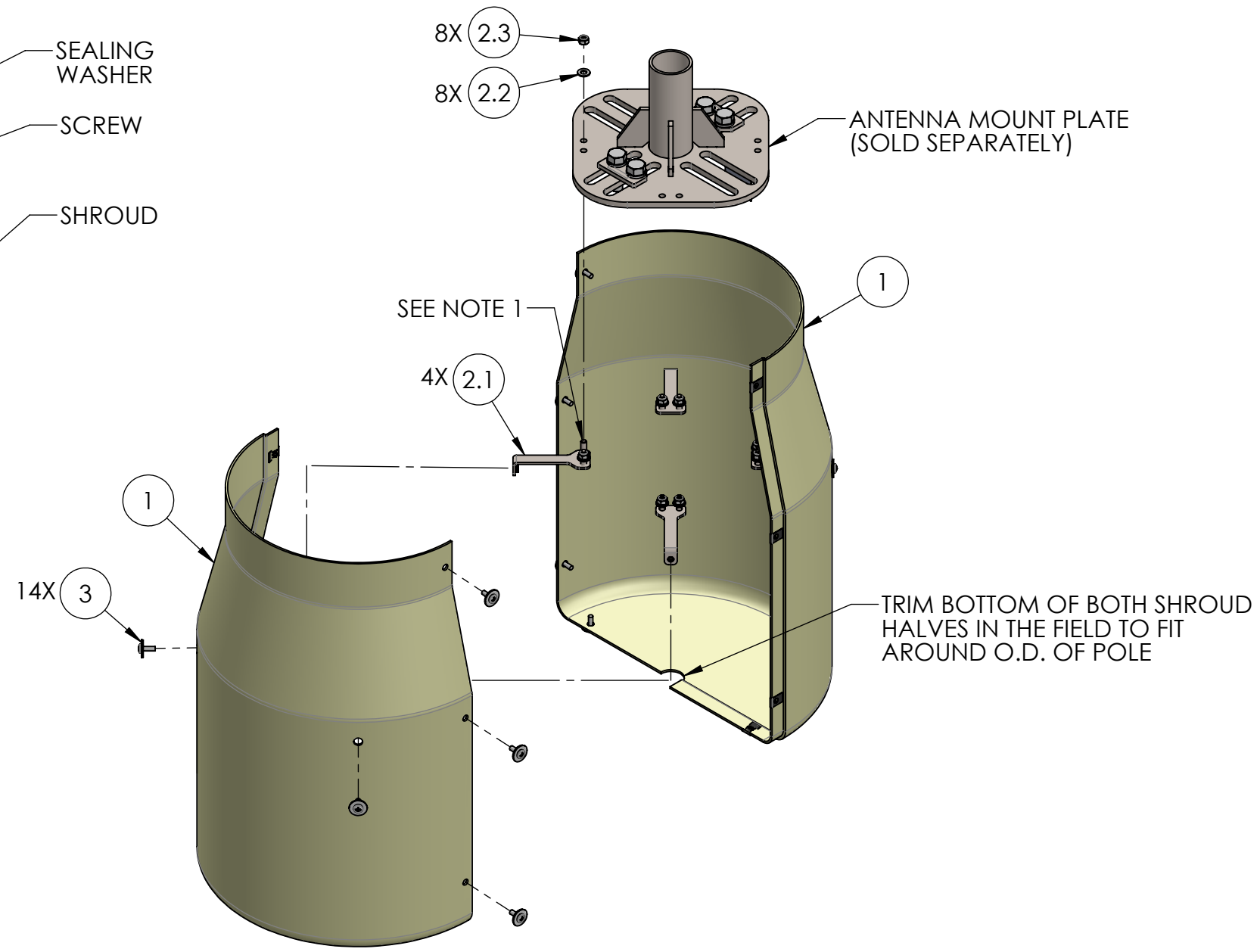

NOTES:

1. STAINLESS STEEL HARDWARE SHALL HAVE ANTISEIZE LUBRICANT APPLIED BEFORE ASSEMBLY.

ITEM NO.	QTY.	DESCRIPTION
1	2	ASSY, SHROUD HALF, DOUBLE HOLE
2	1	KIT, WIDE DIAMETER SHROUD BRACKETS AND HARDWARE
2.1	4	PEM ASSY, SHROUD BRACKET
2.2	8	WASHER, FLAT, 5/16", 18-8 SS
2.3	8	NUT, NYLOCK, 5/16"-18, 18-8 SS
3	12	ASSY, WASHER, SEALING, 1/4", 18-8 SS, 1" O.D., PHMS, 1/4"-20 X 3/4" LG, 18-8 SS

ConcealFab
Corporation

10205 FEDERAL DRIVE
COLORADO SPRINGS, CO 80908
PH: 719-599-3400 FX: 719-599-0057
SALES@CONCEALFAB.COM

PROPRIETARY INFORMATION
USE, REPRODUCTION, OR DISCLOSURE IS SUBJECT TO RESTRICTIONS SET FORTH IN NON-DISCLOSURE AGREEMENTS AND PERTINENT CONTRACTUAL DOCUMENTS.
© 2017 ConcealFab Corp - All Rights Reserved

DO NOT SCALE DWG

DIMENSIONS ARE IN INCHES

MODELED BY:	ALB	DATE:	09/04/19
DRAWN BY:	ALB	DATE:	09/04/19
CHECKED BY:	JAM	DATE:	09/04/19

TITLE: 16" CABLE CONCEALMENT SHROUD, WIDE DIAMETER MOUNT

SCALE:	SHEET SIZE:	SHEET:
1:7	B	2 OF 2

SALES NUMBER:
900021-F